

ENERGY MODEL OF SENSOR NODES IN WSN

Dan LOZNEANU*, Gheorghe PANA*, Ecaterina-Liliana MIRON**

*"Transilvania" University, Brasov, Romania, **"Henri Coanda" Air Force Academy, Brasov, Romania

Abstract: *Wireless sensor networks (WSN) are currently an area of great interest in research, industry and academia. They are no longer just an alternative, but are used even where wired communications are possible. Currently, energy models for the characterization of the nodes used in WSN cannot generate an accurate energy estimation that can be used to design these networks. Requirements like long service life with minimum energy represent the key to implementing new solutions.*

Keywords: *wireless sensor nodes, energy, model.*

1. INTRODUCTION

The potential of this technology is now easy to see with all the inherent difficulties posed. Rapid advances in microelectromechanical systems (MEMS) and radio frequency (RF) have allowed the development of microsensors that can be interconnected in the network with lower power consumption at a smaller price. A WSN consists of hundreds to thousands of nodes that are interconnected via a wireless environment.

Sensor Networks represent an improvement over traditional sensors, which are prepared in terms of space in two ways (Intanagonwiwat, Govindan, Estrin, 2000):

- Sensors that are placed at great distances from the source of the signal which is acquired are large and complex techniques are used to distinguish the source from the ambient environmental noise.

- Several sensors are placed as nodes of information acquisition. These nodes collect data and transmit them to a data concentrator which analyzes and processes data.

To achieve these networks, the communication protocols need techniques used in ad hoc networks, and even if several such ad-hoc protocols have been studied, simulated and implemented they are not suitable for WSN, which may have a number thousands or millions of nodes, and some of

the differences in the needs of the WSN networks are ad hoc (Perkins, 2001):

- Sensor nodes are placed with high spatial density and their number is several times higher compared to ad hoc network.

- These nodes are subjected to increased opportunities for error.

- WSN topologies are changed frequently.

- Broadcast type communication is needed (ad hoc networks are based on point to point communications).

- These nodes do not must have to have a globally unique identifier due to increased overhead and large number of sensor nodes.

One of the major constraints of these networks, on which the work of this paper is directed, is the low energy requirement, especially if the implementation orientation is toward the use of non-renewable energy sources and irreplaceable ones. For this reason, the design of WSN nodes should be especially directed toward energy conservation in terms of hardware, operating system and in terms of communication protocol the efficiency bit/Watt must be highest while respecting the requirements of that system.

2. WIRELESS SENSOR NODES ARCHITECTURE

At the design stage when the components of a wireless node are chosen, the decisive

factors are the size, cost and energy. Computational power and communication in general are considered to be of acceptable quality. To achieve a correct model which can be used in developing and implementing solutions modeling and correlation of all the blocks of a sensor node is necessary. A WSN node integrates the sensor, signal processing, data collection and data storage, information processing, wireless communication and power source. A typical micro-architecture is shown in Figure 1.

In general, each node consists of four components:

- Power supply - minimum stage consists of a DC / DC converter, the system can optionally have the following components:
 - o Battery;
 - o Renewable energy source.
- Sensor unit - consisting of sensors, actuators and A / D converter;
- Processing unit - may be a microcontroller (MCU) or a microprocessor (like Intel Strong ARM, Microchip and Atmel AVR);
- Communication unit - consists of a short range RF circuit, which carries out data transmission and reception.

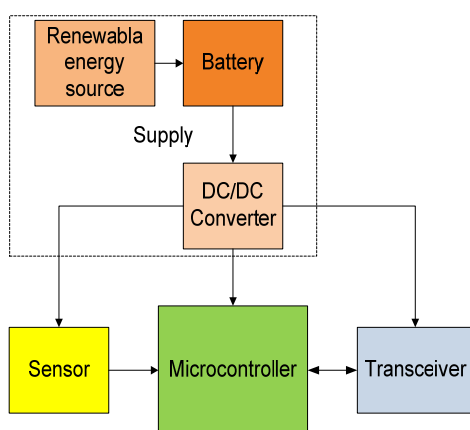

Fig. 1 Architecture of a wireless sensor node

There is a wide range of hardware components that are available on the market and which fit within the range of low energy products, therefore it is very important to establish detailed specifications nodes, which then leads to a detailed study of possible physical implementations

3. GLOBAL ENERGY MODELS FOR WSN

A WSN The current models are made with very much effort for modeling protocols in these networks, and are implemented on the basis of traditional energy models and generate inaccurate results with. Some of the platforms currently available are: OMNet, TOSSIM, PowerTOSSIM, SensorSim.

Energy modeling of WSN nodes is traditionally based on the theoretical energy consumption of existing platforms or analysis modules implemented. By this method a correct modeling in terms of energy consumed by a sense node cannot be achieved accurately. Current trend study of the literature leads to an overwhelming diversity. Currently there is not any standard research process to meet all requirements of such networks.

In paper (Shnayder *et al.*, 2004), was made an energy model based on measurements of execution time for each basic block of instructions, so the model works on the structure of a finite state machine, but this model does not account for the transition state frequency change clock or switching between sleep mode and active mode or idle.

Accurate Prediction of Power Consumption (AEON) is a model proposed in Landsiedel *et al.* (2005), which is focused on prediction of energy consumption as a whole and the network node from which it belongs. The model presented takes into account all possible states of operation of the controller and transceiver, and sensor is considered only for the current active state. The results obtained by them to measure energy consumption of different nodes, following the calibration of the system revealed a variation of 5% of current consumed by different nodes. Differences in estimations of energy consumption for the controller between models AEON and Tossa Power are at 5700%, and in paper Landsiedel *et al.* (2005) was found a lack of accuracy of the abstract model of components.

A global model for defining the sensory nodes in WSN is proposed to be achieved in CAPNET project in December 2010 in which it is assumed that all nodes can be modeled

independently with an application made in Simulink. In the article *Power/Energy Estimator for Designing WSN Nodes with Ambient Energy Harvesting Feature* (Ferry et al., 2011) is proposed the implementation of a power estimation model to determine the WSN nodes autonomy through Functional Level Power Analysis (FLPA) methodology.

4. PROPOSED ENERGY MODEL FOR EVALUATION OF WSN NODES

The fact that most energy models studied are made based on measurements made on practical sensory nodes, and these models conform only to the components used in the implemented hardware configuration and operating algorithm on that type of nodes, these models are not portable, and can be used only for simulation and evaluation of sensory node type for which they were created. For WSN applications are very diverse, and possible applications are endless, so it is necessary to implement a global energy model, generic and portable.

4.1 Energy criterion of renewable energy sources. The general current consumption profile of a sensor node is similar to that in Figure 2, the power consumption during states of sleep and active states can be mediated over time. For a node to operate autonomously sense the average energy scavenged must be greater than or equal to the energy consumed by the node. Average energy (E_{avg}) consumed, is described by the relationship:

$$E_{avg} = n \cdot t_a \cdot P_a + m \cdot t_{sl} \cdot P_{sl} \quad (1)$$

Where P_a is the power consumed by the node in its active state during t_a and n is the rate of occurrence, and P_s that is the power consumed by the node in its inactive state and has the occurrence rate m and lasts for a period equal to t_s .

Given the diversity of energy collection methods, and the wide range of application profiles it is not possible to create a generic model, however, the essential criterion is that the energy stored (E_{st}) in the node must be at least equal with the energy used for its operation in the time interval t_2-t_1 .

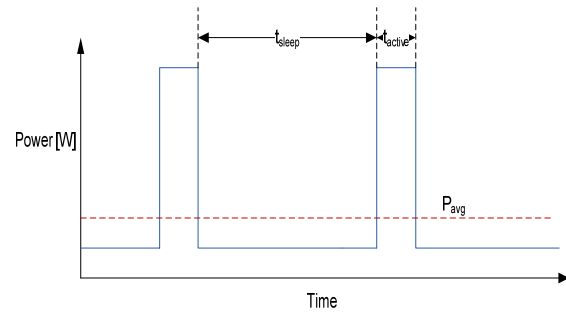

Fig. 2 Generic energy profile of a wireless sensor node

$$E_{st} \geq \int_{t_1}^{t_2} (P_{cons} - P_{scav}) dt \quad (2)$$

where P_{cons} is the power consumed by the sensory node in the time interval t_2-t_1 and P_{scav} is the power collected and stored power in the same timeline.

4.2 The DC-DC converter energy model.

Because it is necessary to use a DC-DC converter, which helps to solve the general problem of battery voltage variation with alteration of capacity due to fixed output voltage, energy modeling of this block is included in this model.

An important technique in power management is introduced by using this block, namely DVS (Dynamic Voltage Scaling). Through this technique is low voltage of the microcontroller, because with lower clock frequency, minimum voltage necessary to ensure its operation and current consumption decreases the microcontroller remains relatively constant. This method leads to a reduced power consumption in sleep states of sensory node.

An important feature of DC-DC converters is that regardless of domestic architecture, the efficiency of these circuits varies depending on the most current consumed and then depending on supply voltage.

Given the diversity components on the market, the best solution is to create a matrix $\eta_{DC-DC}(V_{in}, V_{out}, I_{out}, t)$, from which the values of the converter efficiency are extracted during the simulation of the behavior in time, copesponding to the values of the current

through the load, voltage at the input and at the output of the DC-DC converter.

4.3 The energy model of the control unit and information processing. The microcontroller is the component of a wireless sensor node, which is designed to control node sensory states, to process information, realize transfer tasks and traffic control over the wireless network. Generally, the energy consumed by the microcontroller in a time t , can be described as the sum of energy consumed in all possible functional states of the microcontroller and the amount of energy consumed in all states of transition; in this energy model the proposed relations are:

$$E_{\mu C}(t) = \sum_{i=1}^n E_{st,\mu C,i}(t) + \sum_{j=1}^m E_{tr,\mu C,j}(t) \quad (3)$$

$$E_{\mu C}(t) = \sum_{i=1}^n P_{st,\mu C,i} \cdot T_{st,\mu C,i} \cdot p_{st,\mu C,i} + \sum_{j=1}^m P_{tr,\mu C,j} \cdot T_{tr,\mu C,j} \cdot p_{tr,\mu C,j} \quad (4)$$

$$t = \sum_{i=1}^n T_{st,\mu C,i} + \sum_{j=1}^m T_{tr,\mu C,j} \quad (5)$$

$$\sum_{i=1}^n p_{st,\mu C,i} + \sum_{j=1}^m p_{tr,\mu C,j} = 1 \quad (6)$$

where:

$E_{\mu C}(t)$ - the energy consumed by the microcontroller during t ;

$E_{st,\mu C,i}(t)$ - the energy consumed in the functional state i ;

$E_{tr,\mu C,j}(t)$ - the energy consumed in the transitional state j ;

$P_{st,\mu C,i}$ - power consumption in the functional state i ;

$P_{tr,\mu C,j}$ - power consumption in transitional state j ;

$T_{st,\mu C,i}$ - the duration in functional state i ;

$T_{tr,\mu C,j}$ - the time required for the transition state j ;

$p_{st,\mu C,i}$ - probability of functional state i ;

$p_{tr,\mu C,j}$ - probability of transition j ;

n - number of states functional block;

m - number of transitional states of the block.

4.4 The communication unit energy model. The transceiver unit of communication is used for exchanging information between nodes of WSN. Because full-duplex communication is not required, data transmission and reception are achieved by sequential processes of the network terminal equipment, and practical considerations transmitter and receiver are implemented in the same functional block on the same chip.

In order to offer the possibility of simulation for this block, the approach is similar to that described for the microcontroller, and the energy consumed is calculated by the following relations:

$$E_{trsv}(t) = \sum_{i=1}^n E_{st,trsv,i}(t) + \sum_{j=1}^m E_{tr,trsv,j}(t) \quad (7)$$

$$E_{trsv}(t) = \sum_{i=1}^n P_{st,trsv,i} \cdot T_{st,trsv,i} \cdot p_{st,trsv,i} + \sum_{j=1}^m P_{tr,trsv,j} \cdot T_{tr,trsv,j} \cdot p_{tr,trsv,j} \quad (8)$$

$$t = \sum_{i=1}^n T_{st,trsv,i} + \sum_{j=1}^m T_{tr,trsv,j} \quad (9)$$

$$\sum_{i=1}^n p_{st,trsv,i} + \sum_{j=1}^m p_{tr,trsv,j} = 1 \quad (10)$$

where $E_{trsv}(t)$ represents the energy consumed by the communication block during t .

4.5 The sensor unit energy model. Energy consumption of any type of sensor can be generally described as:

$$E_{sns}(t) = \sum_{i=1}^n E_{st,sns,i}(t) + \sum_{j=1}^m E_{tr,sns,j}(t) \quad (11)$$

$$E_{sns}(t) = \sum_{i=1}^n P_{st,sns,i} \cdot T_{st,sns,i} \cdot p_{st,sns,i} + \sum_{j=1}^m P_{tr,sns,j} \cdot T_{tr,sns,j} \cdot p_{tr,sns,j} \quad (12)$$

where $E_{sns}(t)$ - the energy consumed by sensory block during time t .

4.6 Correlation, simulation of sensor blocks with energy models and comparison with experimental results. To describe the energy behavior of a sensor node is needed correlating behavior of its constituent blocks, because the microcontroller is in active state

whenever at least one of the other two major blocks, and the sensor transceiver are active.

General architecture of wireless sensor nodes is designed around a single power supply, which for the periods in which transceiver and sensor are not used, when they are either stopped by electronic switches, or set into sleep state, it is ideally to be set to generate a lower output voltage through DVS technique because the energy efficiency of the microcontroller will increase during these periods of sleep states. Energy consumed by sensory node will be calculated by correlating the results obtained by previous calculations and will be represented by:

$$E_{\text{node}}(t) = \sum_{k=0}^t \frac{E_{\mu\text{C}}(k) + E_{\text{trsv}}(k) + E_{\text{sns}}(k)}{\eta_{\text{DC-DC}}(V_{\text{in}}, V_{\text{out}}, I_{\text{out}}, k)} \quad (13)$$

To validate the model that takes into account energy consumption during transient states of the wireless sensor nodes components, we used a CC1100 transceiver, which communicates to 868MHz with MSK modulation type and a Microchip Extreme Low Power microcontroller, PIC18LF4622, running at a frequency of 8MHz in active mode.

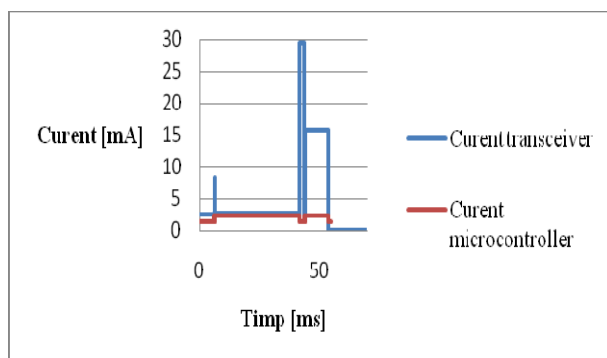

Fig. 3 The result of current consumption simulation for CC1100 and PIC18LF4622 during a packet communication

The simulation results shown in Fig.3, presents the behavior of the radio module in a wireless node. So, by this method of calculation the result obtained is similar with the waveform obtained by measuring the current consumed by the same transceiver and/or microcontroller in Fig.4.

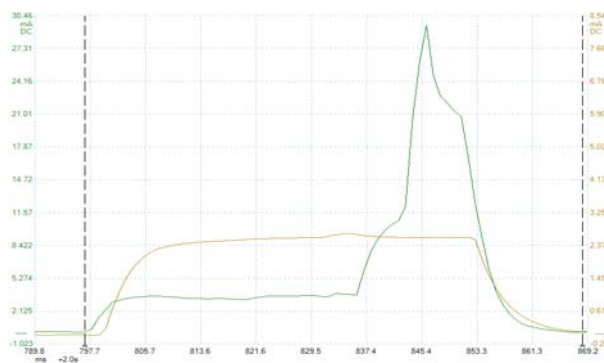

Fig. 4 The result of measured current consumption for CC1100 and PIC18LF4622 during a packet communication

Table 1 Experimental results compared with simulation results for microcontroller and transceiver

Average current[mA]	Sim	Exp	Err
μC	1,96	1,94	1,00
Transceiver	6,10	6,19	-1,52
Total current	8,06	8,14	-0,92

The results of calculation for energy consumption model of a wireless sensor node presented in Table 1, shows that the proposed modeling method generates less than 2% deviation from the results obtained by measuring the two components of the current node. It may be noted that this model generates a global 1% accuracy from experimental results.

5. CONCLUSIONS

Unlike current version of the simulation model for calculating the energy consumption of a wireless sensor node, actual model does not provide the only the energy consumption of the nodes based on measurements made only to meet the hardware and operating algorithm of a type of node, but this proposed model is a mathematical approach for each part of the wireless sensor node, which is adaptable to any sensor node that will be or has been developed. Because WSN applications are very diverse, and possible applications are endless, it is necessary to implement a global energy model, generic and portable.

Simulation with the proposed model for the microcontroller and transceiver blocks and the measurements made have brought out that the

deviations decrease to levels below 1% by using this model that takes into account the transitional stages of operation and thus it is made an improvement of more than 2% compared to the models that do not take into account the transitional stages of operation for the building blocks of a wireless sensor node.

BIBLIOGRAPHY

1. Ferry, N., Ducloyer, S., Julien, N., Jutel, D. (2011) *Power/Energy Estimator for Designing WSN Nodes with Ambient Energy Harvesting Feature*. Hindawi Publishing Corporation, Vol. EURASIP Journal on Embedded Systems.
2. Intanagonwiwat, C., Govindan, R., Estrin, D. (2000) *Directed diffusion: a scalable and robust communication paradigm for sensor networks*. Boston, MA: Proceedings of the ACM MobiCom'00.
3. Landsiedel, O., Wehrle, K., Gotz, S. (2005) *Accurate Prediction of Power Consumption in Sensor Networks*. Embedded Networked Sensors, EmNetS-II. The Second IEEE Workshop.
4. Perkins, Charles, E. C. (2001) *Ad Hoc Networks*. Boston, MA: Addison-Wesley Professional.
5. Shnayder, V., Hempstead, M., Bor-rong, C., Werner, A. G., Welsh, M. (2004) *Simulating the Power Consumption of LargeScale Network Applications*. Cambridge, MA: Harvard University.